

4" O.D. PIPE=18.2" THRU 48.8"  
 6" O.D. PIPE=19.5" THRU 48.1"  
 8" O.D. PIPE=20.7" THRU 54.9"  
 10" O.D. PIPE=21.0" THRU 52.6"  
 12" O.D. PIPE=21.5" THRU 53.5"

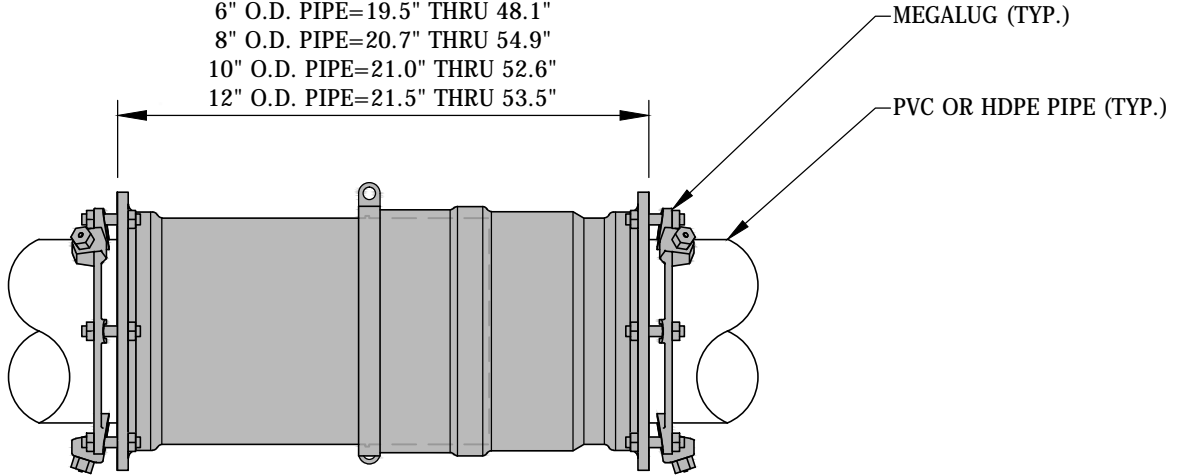

STANDARD UNIT (2.5" MOVEMENT MAX.)

4" O.D. PIPE=20.6" THRU 51.2"  
 6" O.D. PIPE=20.4" THRU 49.0"  
 8" O.D. PIPE=21.4" THRU 55.6"  
 10" O.D. PIPE=21.5" THRU 49.5"  
 12" O.D. PIPE=24.2" THRU 56.2"

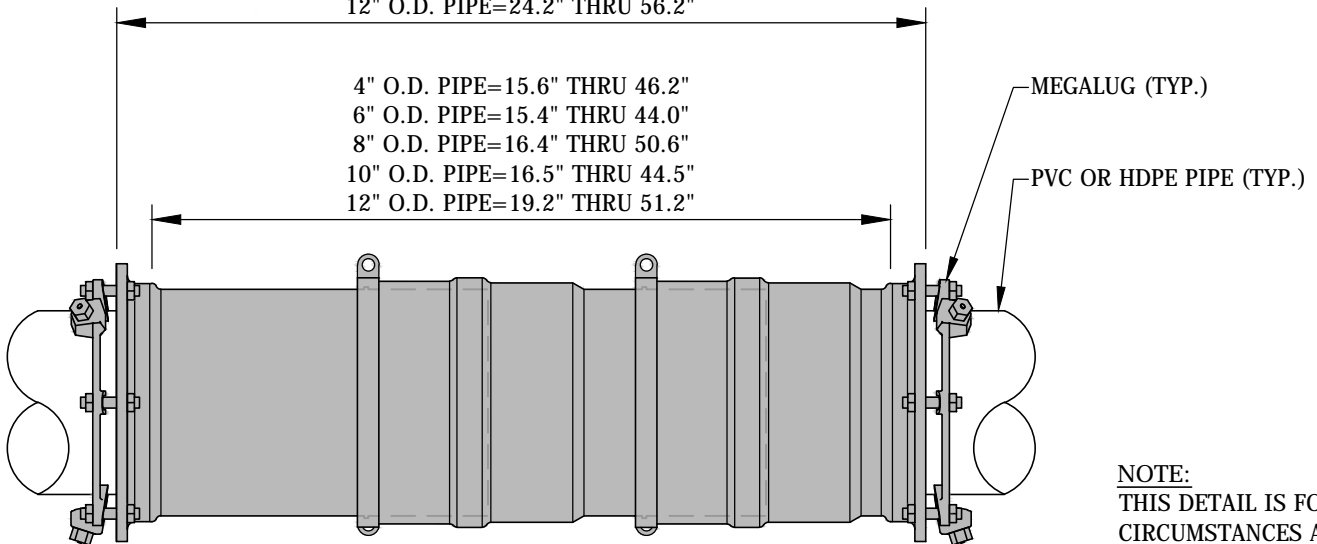

UNIT WITH ONE ADDITIONAL SLEEVE (5" MOVEMENT MAX.)

**NOTE:**  
 THIS DETAIL IS FOR SPECIAL CIRCUMSTANCES AND ONLY INTENDED FOR AREAS THAT HAVE EXHIBITED EXPANSION OR CONTRACTION ISSUES. E.W.S.U. WILL MAKE FINAL DETERMINATION IF NEEDED.

File: F:\ENGINEER\AUTOCAD\Standards\Detail Drawings\Water\DW08 Expansion Coupling 4in Through 12in.dwg



## EXPANSION COUPLING (4" THROUGH 12")

Approved: 11/10/15

Adopted: 11/10/15

Figure

Approved By: Michael D. Labitzke, P.E.

Scale: N.T.S.

DW08